



SEATTLE, WASHINGTON
 1.800.426.9794
 PHONE 253.627.2910 · FAX 253.926.4660

LOS ANGELES, CALIFORNIA
 1.800.624.8073
 PHONE 323.588.2688 · FAX 323.588.1767

CANTON, OHIO
 1.800.822.6358
 PHONE 330.833.5800 · FAX 330.833.5815

HARTFORD, CONNECTICUT
 1.800.641.4140
 PHONE 860.688.8393 · FAX 860.683.2337

WWW.SSA-CORP.COM
 EMAIL: SALES@SSA-CORP.COM

WICHITA, KANSAS
 1.800.426.9794
 PHONE 316.768.4040 · FAX 316.821.9125

TITANIUM DATA SHEET

Service Steel Aerospace (SSA) is one of the largest titanium distributors in the World. SSA stocks titanium mill products for the Aerospace Industry, Oil Field, Biomedical, Racing and other critical application industries. We rely on our vast inventory and mill relationships to offer immediate delivery on all of our mill products. SSA places the highest value on quality, customer service and customer satisfaction.

ALLOYS

Titanium Alloy	Specifications
6Al-4V	AMS 4928, AMS 6931, ASTM B-348, AMS 4911, AMS 4965, AMS 6930, AMS 4967, MIL-T-9047, AMS-T-9047, MIL-T-9046, AMS-T-9046, AMS 4920, BMS 7-269, ASTM-F-1472, DMS 1583, DMS 1570, DMS 1592
6Al-4V ELI	AMS 4905, AMS 4907, AMS 4930, AMS 4931, AMS 6932, BMS 7-269, ASTM-F-136
6Al-6V-2Sn	AMS 4971, AMS 4978, AMS 4979, AMS 6935, AMS 6936, AMS 4918
6Al-2Sn-4Zr-2Mo	AMS 4975, AMS 4976, MIL-T-9047, AMS 6905, AMS 4919
6Al-2Sn-4Zr-6Mo	AMS 4981, AMS 6906, AMS 6907
8Al-1Mo-1V	AMS 4972, AMS 4973
10V-2Fe-3Al	AMS 4984, AMS 4986, AMS 4987

PRODUCTS

Service Steel Aerospace's (SSA) extensive inventory of ingot and billet allows SSA to competitively support rolled plate, rounds, forged rounds, and open-die custom "on size" block forgings at less than mill lead time and no mill minimums. SSA also offers value added processing such as heat treating, trepanning, water jet cutting, sonic inspection and mechanical testing.

QUALITY/OEM APPROVALS

Service Steel Aerospace (SSA) is **ISO 9001** and **AS9100** certified and operates under a quality system that is approved by leading manufacturers such as Boeing, Northrop-Grumman, Lockheed-Martin, Goodrich, Baker Hughes, Halliburton, Bombardier, as well as many others. SSA's commitment to quality ensure that our customers receive the right product every time.

TECHNICAL DATA SHEET

GENERAL CHARACTERISTICS

Titanium's unique combination of physical, mechanical and corrosion resistant properties makes it an ideal material for many different applications. Titanium's high strength to weight ratios makes titanium the prime choice for high strength, lightweight applications.

CHEMISTRY - MOST COMMON ALLOYS

Element	6Al-4V		6Al-4V ELI		6Al-2Sn-4Zr-2Mo		6Al-2Sn-4Zr-6Mo		6Al-6V-2Sn	
	min	max	min	max	min	max	min	max	min	max
Aluminum	5.50	6.75	5.50	6.50	5.50	6.50	5.50	6.50	5.00	6.00
Vanadium	3.50	4.50	3.50	4.50	--	--	--	00	5.00	6.00
Iron	--	0.30	--	0.25	--	0.10	--	0.15	0.35	1.00
Oxygen	--	0.20	--	0.13	--	0.15	--	0.15	--	0.20
Carbon	--	0.08	--	0.08	--	0.05	--	0.04	--	0.05
Zirconium	--	--	--	--	3.60	4.40	3.50	4.50	--	--
Molybdenum	--	--	--	--	1.80	2.20	5.50	6.50	--	--
Tin	--	--	--	--	1.80	2.20	1.75	2.25	1.50	2.50
Silicon	--	--	--	--	0.06	0.10	--	--	--	--
Copper	--	--	--	--	--	--	--	--	0.35	1.00
Nitrogen	--	0.05	--	0.05	--	0.05	--	0.04	--	0.04
Hydrogen	--	0.0125	--	0.0125	--	0.0125	--	0.0125	--	0.015
Yttrium	--	0.005	--	0.005	--	0.005	--	0.005	--	0.005
Other Elements, each	--	0.10	--	0.10	--	0.10	--	0.10	--	0.10
Other Elements, total	--	0.40	--	0.40	--	0.30	--	0.40	--	0.30
Titanium	remainder		remainder		remainder		remainder		remainder	

PHYSICAL PROPERTIES

	6Al-4V	6Al-4V ELI	6Al-6V-2Sn	6Al-2Sn-4Zr-2Mo	6Al-2Sn-4Zr-6Mo
density (lbs/in ³)	0.163	0.163	0.164	0.164	0.168
Tensile (ksi)	130	120	145	130	165
Yield (ksi)	120	110	135 to 160	120	155
Elong %	10	8	8	10	6
RofA	20	15	15	25	12

WEIGHT FORMULAS

(Bar weights based on: steel, .2833 lb. per cubic in./titanium, .1600 per cubic in./nickel alloy .2970 lb. per cubic in.)

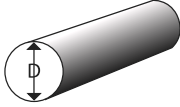
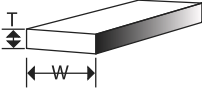
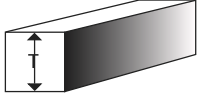
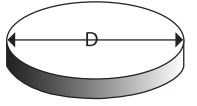
ROUNDS	FLATS	SQUARES	CIRCLES
 <p>Steel: Lbs. per lineal foot = $D^2 \times 2.669$ Lbs. per lineal inch = $D^2 \times .2224$</p> <p>Titanium: Lbs. per lineal foot = $D^2 \times 1.507$ Lbs. per lineal inch = $D^2 \times .1256$</p> <p>Nickel Alloy: Lbs. per lineal foot = $D^2 \times 2.798$ Lbs. per lineal inch = $D^2 \times .2331$</p>	 <p>Steel: Lbs. per lineal foot = $T \times W \times 3.40$ Lbs. per lineal inch = $T \times W \times .2833$</p> <p>Titanium: Lbs. per lineal foot = $T \times W \times 1.92$ Lbs. per lineal inch = $T \times W \times .16$</p> <p>Nickel Alloy: Lbs. per lineal foot = $T \times W \times 3.564$ Lbs. per lineal inch = $T \times W \times .2970$</p>	 <p>Steel: Lbs. per lineal foot = $T^2 \times 3.40$ Lbs. per lineal inch = $T^2 \times .2833$</p> <p>Titanium: Lbs. per lineal foot = $T^2 \times 1.92$ Lbs. per lineal inch = $T^2 \times .16$</p> <p>Nickel Alloy: Lbs. per lineal foot = $T^2 \times 3.564$ Lbs. per lineal inch = $T^2 \times .2970$</p>	 <p>Steel: Wt. of Circle in lbs. = $D^2 \times T \times .2224$</p> <p>Titanium: Wt. of Circle in lbs. = $D^2 \times T \times .1256$</p> <p>Nickel Alloy: Wt. of Circle in lbs. = $D^2 \times T \times .2331$</p>